



Opposed blades



Closed cell side seals



Encased gears

Multileaf dampers

JZ-LL



For extremely low-leakage shut-off in ventilation and air conditioning systems

Rectangular multileaf dampers for volume flow and pressure control as well as for extremely low-leakage shut-off of ducts and openings in walls and ceiling slabs

- Maximum dimensions 2000 × 1995 mm
- Closed multileaf damper air leakage to EN 1751, classes 3 – 4, depending on size
- Casing air leakage to EN 1751, class C
- Aerofoil opposed action blades
- Closed cell side seals meet increased hygiene requirements
- Blades interconnected by external linkage
- Available in standard sizes and many intermediate sizes

Optional equipment and accessories

- Actuators: Open/close actuators, modulating actuators
- Explosion-proof construction with pneumatic actuator or spring return actuator
- Powder-coated construction

General information	2	Dimensions	11
Function	4	Materials and surfaces	13
Technical data	5	Attachments	14
Quick sizing	6	Product details	17
Specification text	7	Installation details	20
Order code	8	Nomenclature	23
Variants	9		

General information

Application

- Stainless steel and powder-coated construction

Special features

- Aerofoil blades
- Low-maintenance, robust construction
- No parts with silicone
- Available in standard sizes and many intermediate sizes
- Closed cell side seals meet increased hygiene requirements

Classification

- Closed blade air leakage to EN 1751

Test pressure up to 2000 Pa

- Up to B = 599 mm, class 3
- B = 600 – 1000 mm, class 4

Test pressure up to 1000 Pa

- Up to B = 599 mm, class 3
- B = 600 – 2000 mm, class 4

Nominal sizes

- B: 200 – 2000 mm, in increments of 1 mm
- Width subdivided (BM): 2001 – 4150 mm, in increments of 1 mm
- H: 180, 345, 510, 675, 840, 1005, 1170, 1335, 1500, 1665, 1830, 1995 mm (intermediate sizes 183 – 1995 in increments of 1 mm, except for standard size H - 1 mm, H + 1 mm, H + 2 mm)
- Height subdivided (HM): 1999 – 4066 mm, in increments of 1 mm
- Any combination of B × H

Variants

- JZ-LL: Multileaf damper with opposed blade action, made of galvanised sheet steel
- JZ-LL-A2: Multileaf damper with opposed blade action, made of stainless steel

Constructions

- Duct connection
- Corner holes on both sides
- G: Flange holes on both sides

Bearings

- Plastic bearings, operating temperature 0 – 100 °C
- M: Brass bearings, operating temperature 0 – 100 °C
- E: Stainless steel bearings, operating temperature 0 – 100 °C

Blades

- Only for steel or stainless steel multileaf dampers with brass or stainless steel bearings (JZ-...-M, JZ-...-E)
- V: Reinforced blades available as from width 800 mm

Parts and characteristics

- Ready-to-install shut-off damper
- Blades with external linkage
- Drive arm

Attachments

- Quadrant stays and limit switches: Quadrant stays to adjust the damper blades (infinite adjustment) and for capturing the end positions
- Open/close actuators: Actuators for opening and closing multileaf dampers
- Modulating actuators: Actuators for infinite blade blade adjustment
- Pneumatic actuators: Pneumatic actuators for opening and closing multileaf dampers
- Explosion-proof actuators: Actuators for opening and closing multileaf dampers installed in potentially explosive atmospheres

Accessories

- Installation subframe: Installation subframe for the fast and simple installation of multileaf dampers

Construction features

- Rectangular casing, welded (P1: casing with screws), material thickness galvanised steel 1.25 mm, stainless steel A2 = 1.2 mm
- Blades, material thickness 1 mm
- Flanges on both sides, suitable for duct connection, either flange holes or corner holes
- External linkage, robust and durable, consisting of the coupling rod and horizontal arms
- Damper blade shafts, Ø12 mm, with notch to indicate the damper blade position (not for attachment ZS99)
- With drive shaft as an attachment: For the position of the drive shaft see 'Dimensions and weight'
- With actuator as an attachment: The actuator is always attached to the second blade from the top
- Travel stop (angle section) ensures tight closure of the top and bottom blades
- Blade tip seals and side seals
- The construction and selection of materials comply with the criteria stipulated in European directives, referred to as ATEX (for use in potentially explosive atmospheres) for variants with brass or stainless steel bearings (-M, -E)

Materials and surfaces

- Casing and blades made of galvanised sheet steel or stainless steel
- Blade shafts, drive arm and external linkage made of galvanised steel or stainless steel
- Plastic, brass or stainless steel bearings
- Blade tip seals made of PP/PTV plastic
- Side seals made of closed cell PE foam
- P1: Powder-coated, RAL CLASSIC colour
- PS: Powder-coated, DB colour

Standards and guidelines

- Casing air leakage to EN 1751, class C
- Meets the general requirements of DIN 1946, Part 4, with regard to the acceptable closed multileaf damper air leakage
- Multileaf damper sizes from B = 600 mm meet the increased requirements of DIN 1946, Part 4, with regard to the maximum closed multileaf damper air leakage

Maintenance

- Maintenance-free as construction and materials are not subject to wear
- Contamination should be removed as it may lead to corrosion and to increased closed multileaf damper air leakage

Function

Multileaf dampers with external linkage can have parallel action blades or opposed action blades. An external linkage transfers the synchronous rotational movement from the drive arm to the individual blades. Even very large multileaf dampers can be

safely opened and closed with this type of linkage. Opposed action blades close at various speeds as the linkage includes a transverse link. This facilitates the closing process and reduces the closed multileaf damper air leakage.

Schematic illustration of JZ-LL, JZ-LL-A2

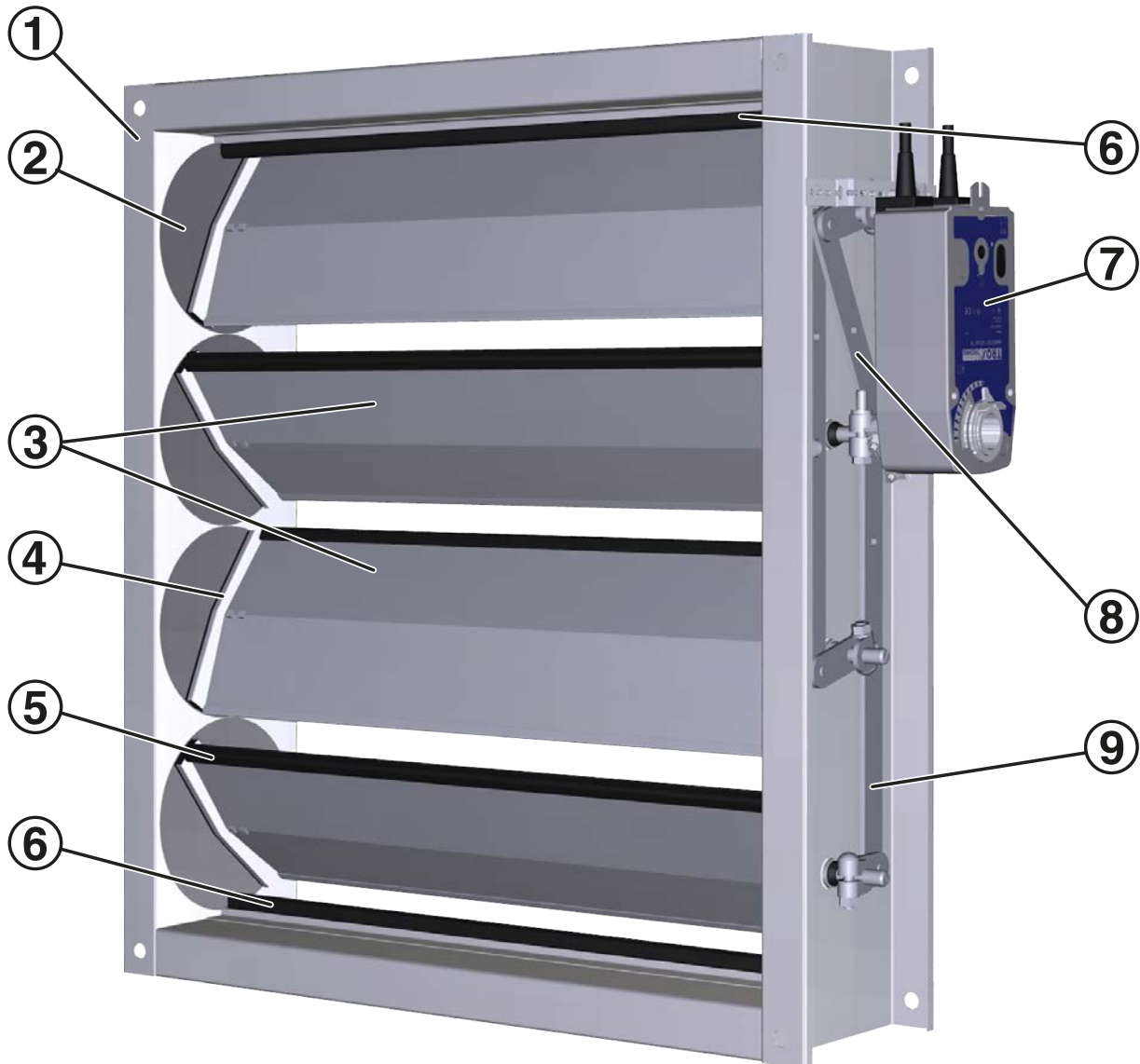

- ① Casing
- ② Slide disc
- ③ Opposed blades
- ④ Side seal
- ⑤ Blade tip seal
- ⑥ Travel stop (angle section with seal)
- ⑦ Actuator
- ⑧ Transverse link
- ⑨ External linkage

Technical data

The torque for actuating multileaf dampers must be dimensioned so that the damper can be safely opened and closed. For closure, the torque must suffice to ensure complete shut-off by the blades.

Opening is initiated without the impact of aerodynamic forces.

When air flows through the damper, the aerodynamic forces of the airflow create a closing force (torque) on the blades; this happens independently of the direction of the airflow. This closing force must be countered, or overcome. The blade angle α with the largest torque depends, among other things, on the fan characteristics.

Nominal sizes	200 × 180 – 2000 × 1995 mm
Operating temperature	0 – 100 °C

JZ-LL, JZ-LL-A2, minimum torques [Nm]

H	B									
	200	400	600	800	1000	1200	1400	1600	1800	2000
180	10	10	10	10	10	10	10	10	10	10
345	10	10	10	10	10	10	10	10	10	10
510	10	10	10	10	10	10	10	10	10	10
675	10	10	10	10	10	10	15	15	15	15
840	10	10	10	10	15	15	15	15	15	15
1005	10	10	15	15	15	15	15	15	20	20
1170	15	15	15	15	15	15	20	20	30	30
1335	15	15	15	15	20	20	30	30	30	30
1500	15	15	15	20	20	30	30	30	30	30
1665	20	20	20	20	30	30	30	30	30	30
1830	20	20	20	20	30	30	30	30	30	30
1995	20	20	20	20	30	30	30	30	30	30

Steel and stainless steel multileaf dampers, free cross-sectional area [m²]

H	B									
	200	400	600	800	1000	1200	1400	1600	1800	2000
180 – 344	0.03	0.06	0.09	0.12	0.15	0.18	0.21	0.24	0.27	0.3
345 – 509	0.06	0.11	0.17	0.23	0.28	0.34	0.4	0.45	0.51	0.57
510 – 674	0.08	0.17	0.25	0.33	0.42	0.5	0.58	0.67	0.75	0.83
675 – 839	0.11	0.22	0.33	0.44	0.55	0.66	0.77	0.88	0.99	1.1
840 – 1004	0.14	0.27	0.41	0.55	0.69	0.82	0.96	1.1	1.23	1.37
1005 – 1169	0.16	0.33	0.49	0.66	0.82	0.98	1.15	1.31	1.47	1.64
1170 – 1334	0.19	0.38	0.57	0.76	0.95	1.14	1.33	1.52	1.72	1.91
1335 – 1499	0.22	0.43	0.65	0.87	1.09	1.3	1.52	1.74	1.96	2.17
1500 – 1664	0.24	0.49	0.73	0.98	1.22	1.47	1.71	1.95	2.2	2.44
1665 – 1829	0.27	0.54	0.81	1.08	1.36	1.63	1.9	2.17	2.44	2.71
1830 – 1994	0.3	0.6	0.89	1.19	1.49	1.79	2.08	2.38	2.68	2.98
1995	0.32	0.65	0.97	1.3	1.62	1.95	2.27	2.6	2.92	3.25

Intermediate sizes: Interpolate values between widths.

Maximum static differential pressure for a closed multileaf damper $\Delta p_{t,max}$ [Pa]

Construction	B						
	800	1000	1200	1400	1600	1800	2000
Standard construction	2500	2000	1650	1400	1250	1100	1000
Brass bearings (-M)	3000	2500	2200	1950	1750	1600	1500
Stainless steel bearings (-E)	3000	2500	2200	1950	1750	1600	1500
Reinforced blades (-M-V, -E-V) 3	3500	3000	2700	2500	2300	2100	2000

JZ-LL, JZ-LL-A2, sound power level for a closed multileaf damper L_{WA} [dB(a)]

Δp_t [Pa]	Area $B \times H$ [m ²]							
	0.14	0.2	0.4	0.6	0.8	1.2	2	4
100	<35	35	38	39	41	42	45	48
200	41	42	45	47	48	50	53	56
500	51	52	55	57	58	60	62	65
1000	58	60	63	64	66	68	70	>70
1500	63	64	67	69	>70	>70	>70	>70
2000	65	67	70	>70	>70	>70	>70	>70

Quick sizing

Quick sizing tables provide a good overview of the sound power levels and differential pressures that can be expected. Approximate intermediate values can be interpolated. Precise intermediate values and spectral data can be calculated with our Easy Product Finder design program.

The sound power levels L_{WA} apply to multileaf dampers with a cross-sectional area ($B \times H$) of 1 m².

The differential pressures apply to multileaf dampers installed in ducts (installation type A).

Installation type

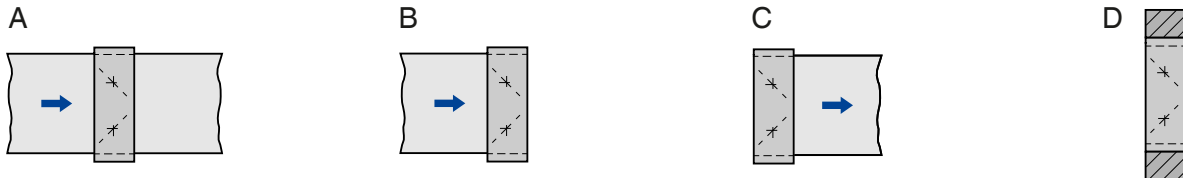

A = Ducts on both sides

B = Air discharge

C = Air intake

D = Air transfer

JZ-LL, JZ-LL-A2, JZ-HL, differential pressure and sound power level

v [m/s]	Damper blade position α									
	OPEN		20°		40°		60°		80°	
	Δp_t [Pa]	L_{WA} [dB(A)]	Δp_t [Pa]	L_{WA} [dB(A)]	Δp_t [Pa]	L_{WA} [dB(A)]	Δp_t [Pa]	L_{WA} [dB(A)]	Δp_t [Pa]	L_{WA} [dB(A)]
0.5	<5	<30	<5	<30	<5	7.5	22	34	250	63
1	<5	<30	<5	<30	8	26	85	53	1000	83
2	<5	<30	<5	<30	30	46	345	73	>2000	>90
4	<5	41	10	44	120	65	1385	>90	>2000	>90
6	<5	52	24	56	270	77	>2000	>90	>2000	>90
8	10	60	42	64	480	85	>2000	>90	>2000	>90

Specification text

This specification text describes the general properties of the product. Texts for variants can be generated with our Easy Product Finder design program.

Rectangular multileaf dampers for volume flow and pressure control as well as for low-leakage shut-off of ducts and openings in walls and ceiling slabs. Ready-to-operate unit which consists of the casing, aerofoil blades and the blade mechanism. Flanges on both sides, suitable for duct connection. The blade position is indicated externally by a notch in the blade shaft extension.

Closed multileaf damper air leakage to EN 1751, class 4 (B ≤ 600 mm, class 3)

Casing air leakage to EN 1751, class C

Special features

- Aerofoil blades
- Low-maintenance, robust construction
- No parts with silicone
- Available in standard sizes and many intermediate sizes
- Closed cell side seals meet increased hygiene requirements

Materials and surfaces

- Casing and blades made of galvanised sheet steel or stainless steel
- Blade shafts, drive arm and external linkage made of galvanised steel or stainless steel
- Plastic, brass or stainless steel bearings
- Blade tip seals made of PP/PTV plastic
- Side seals made of closed cell PE foam
- P1: Powder-coated, RAL CLASSIC colour
- PS: Powder-coated, DB colour

Constructions

- Duct connection
- Corner holes on both sides
- G: Flange holes on both sides

Bearings

- Plastic bearings, operating temperature 0 – 100 °C
- M: Brass bearings, operating temperature 0 – 100 °C
- E: Stainless steel bearings, operating temperature 0 – 100 °C

Blades

- Only for steel or stainless steel multileaf dampers with brass or stainless steel bearings (JZ-...-M, JZ-...-E)
- V: Reinforced blades available as from width 800 mm

Technical data

- Nominal sizes: 200 × 180 mm – 2000 × 1995 mm
- Operating temperature: 0 to 100 °C

Sizing data

- q_v (m³/h)
- Δp_t [Pa]
- Air-regenerated noise
- L_{PA} [dB(A)]

Order code

JZ-LL - A2 - G - E - ... - L / 1000 × 1005 / ER / Z64 / NC / P1 - RAL ...
 | | | | | | | | | | |
 1 2 3 4 5 6 7 8 9 10 11

1 Type

JZ-LL Low-leakage multileaf damper, closed multileaf damper
 air leakage to EN 1751, class 3 – 4

2 Material

No entry required: Galvanised steel

A2 Stainless steel

3 Duct connection

No entry required: Corner holes on both sides

G Flange holes on both sides (no corner holes)

4 Bearings

No entry required: Plastic bearings

M Brass bearings

E Stainless steel bearings

5 Construction of blades

Only for steel or stainless steel multileaf dampers with brass or
 stainless steel bearings

V Reinforced blades available from width 800 mm

6 Operating side

No entry required: On the right

L Left

7 Nominal size [mm]

B × H

B > 2000 = width subdivided

H > 1995 = height subdivided

Order example: JZ-LL-G-L/1200×675/ER/ZF06/NC

Material	Galvanised steel
Duct connection	Flange holes on both sides
Bearings	Plastic bearings
Construction of blades	Standard
Operating side	Left
Nominal size	1200 × 675 mm
Installation subframe	With
Attachments	Spring return actuator, 20 Nm, 24 V AC/DC
Damper blade position	Power off to CLOSE
User interface	Standard construction

8 Installation subframe

No entry required: None

ER With (only for duct connection G)

9 Attachments

No entry required: None

Z04 – Z07 Hold open device

Z12 – Z51 Actuators

ZF01 – ZF15 Spring return actuators

Z60 – Z77 Pneumatic actuators

Explosion-proof actuators

Z1EX, Z3EX Electrical

Z60EX – Z77EX Pneumatic

10 Damper blade safety function

Only for spring return actuators or pneumatic actuators

NO Pressure off/power off to OPEN

NC Pressure off/power off to CLOSE

11 Surface

No entry required: Standard construction

P1 Powder-coated, specify RAL CLASSIC colour

Gloss level

RAL 9010 50 %

RAL 9006 30 %

All other RAL colours 70 %

Variants

Multileaf damper, variant JZ-LL



Multileaf damper with explosion-proof actuator

JZ-LL

Variant

- JZ-LL: Multileaf damper with opposed blade action, made of galvanized sheet steel

Materials and surfaces

- Casing and blades made of galvanized sheet steel or stainless steel
- Blade shafts, drive arm and external linkage made of galvanized steel or stainless steel
- Blade tip seals made of PP/PTV plastic
- Side seals made of closed cell PE foam
- P1: Powder-coated, RAL CLASSIC colour
- PS: Powder-coated, DB colour

Multileaf damper, variant JZ-LL-A2

Multileaf damper with actuator

JZ-LL-A2**Variant**

- JZ-LL-A2: Multileaf damper with opposed blade action, made of stainless steel

Materials and surfaces

- Casing and blades made of galvanised sheet steel or stainless steel
- Blade shafts, drive arm and external linkage made of galvanised steel or stainless steel
- Blade tip seals made of PP/PTV plastic
- Side seals made of closed cell PE foam
- P1: Powder-coated, RAL CLASSIC colour
- PS: Powder-coated, DB colour

Dimensions

JZ-LL, standard sizes

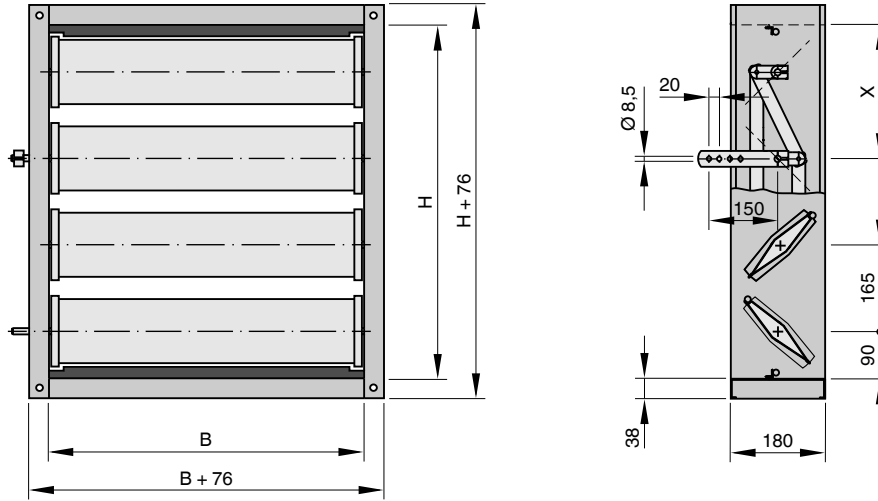

Illustration shows operating side on the right

JZ-LL, standard sizes

H	No. of blades	Spindle position	
		X	Damper blade
180	1	90	1
345	2	255	2
510	3	255	2
675	4	255	2
840	5	255	2
1005	6	255	2
1170	7	255	2
1335	8	255	2
1500	9	255	2
1665	10	255	2
1830	11	255	2
1995	12	255	2

JZ-LL, intermediate sizes

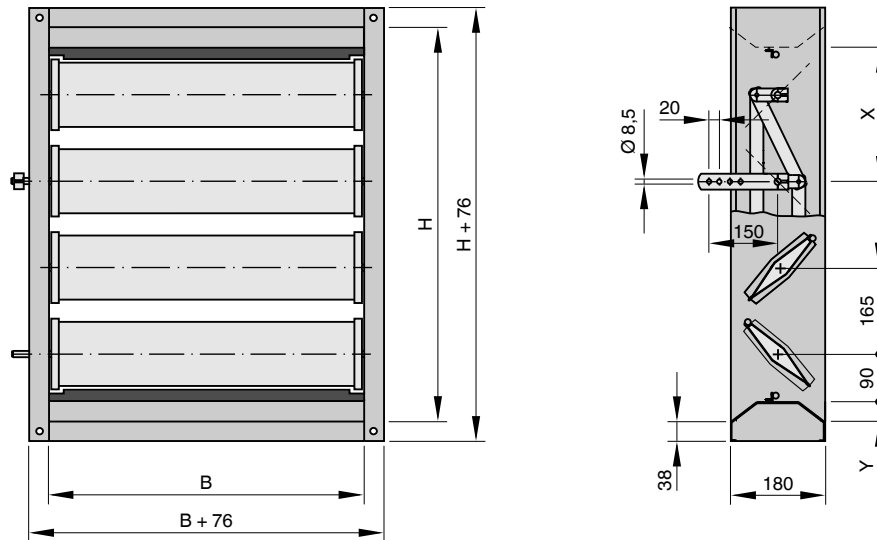

Illustration shows operating side on the right

JZ-LL, intermediate sizes

H	No. of blades	Spindle position		Y [mm]
		X	Damper blade	Y
183 – 343	1	90	1	1.5 – 81.5
348 – 508	2	255	2	1.5 – 81.5
513 – 673	3	255	2	1.5 – 81.5
678 – 838	4	255	2	1.5 – 81.5
843 – 1003	5	255	2	1.5 – 81.5
1008 – 1168	6	255	2	1.5 – 81.5
1173 – 1333	7	255	2	1.5 – 81.5
1338 – 1498	8	255	2	1.5 – 81.5
1503 – 1663	9	255	2	1.5 – 81.5
1668 – 1828	10	255	2	1.5 – 81.5
1833 – 1993	11	255	2	1.5 – 81.5

JZ, JZ-LL, JZ-HL, weights [kg]

H	B										
	200	400	600	800	1000	1200	1400	1600	1800	2000	
180	4	6	8	9	11	13	14	16	18	19	
345	6	8	10	12	15	17	19	21	24	26	
510	7	10	13	16	19	22	25	27	30	33	
675	10	13	16	20	23	27	30	33	37	40	
840	11	15	19	23	28	32	37	41	46	50	
1005	11	17	22	27	32	38	43	48	53	59	
1170	13	19	25	31	37	43	49	55	61	67	
1335	15	22	28	35	41	48	55	61	68	74	
1500	16	23	30	37	44	51	59	66	73	80	
1665	17	25	33	41	49	57	65	72	80	88	
1830	18	27	35	44	52	61	69	78	86	95	
1995	19	29	38	47	56	66	75	84	94	103	

Materials and surfaces

Material

Order code detail	Part	Material
-	Enclosure	Galvanised sheet steel
-	Blades	Galvanised sheet steel
-	Shafts	Galvanised steel
-	Drive arm	Galvanised steel
-	Linkage	Galvanised steel
-	Long-side blade tip seals	Plastic PP/PTV
-	Front blade side seals	Closed cell PE foamed plastic
-	Bearings	Plastic
A2	Enclosure	Stainless steel, material no. 1.4301
A2	Blades	Stainless steel, material no. 1.4301
A2	Shafts	Stainless steel, material no. 1.4305
A2	Drive arm	Stainless steel, material no. 1.4301
E	Linkage	Stainless steel
M	Linkage	Brass

Surfaces

Order code detail	Part	Material
-	Enclosure	Untreated
P1-RAL ...	Blades	Powder-coated, colour RAL ... CLASSIC
PS-DB ...	Blades	Powder-coated, colour DB ...

Attachments

Quadrant stays and limit switches

Order code detail	Description	Limit switch	Function
Z04	Hold open device	–	
Z05	Hold open device	1	Damper blade position CLOSED
Z06	Hold open device	1	Damper blade position OPEN
Z07	Hold open device	2	Damper blade positions CLOSED and OPEN

Open/close actuators

Order code detail	Description	Function	Supply voltage	Torque	Auxiliary switch
Z12	SM230A	1-wire-control 2-wire-control (3-point)	100 – 240 V AC	20 Nm	–
Z13	GM230A	1-wire-control –2-wire-control (OPEN-CLOSE)	100 – 240 V AC	40 Nm	–
Z14	SM24A	1-wire-control 2-wire-control (3-point)	24 V AC/DC	20 Nm	–
Z15	GM24A	1-wire-control –2-wire-control (OPEN-CLOSE)	24 V AC/DC	40 Nm	–
Z16	SM230A	1-wire-control 2-wire-control (3-point)	100 – 240 V AC	20 Nm	S2A
Z17	GM230A	1-wire-control 2-wire-control (3-point)	100 – 240 V AC	40 Nm	S2A
Z18	SM24A	1-wire-control 2-wire-control (3-point)	24 V AC/DC	20 Nm	S2A
Z19	GM24A	1-wire-control 2-wire-control (3-point)	24 V AC/DC	40 Nm	S2A
Z43	NM230A	1-wire-control 2-wire-control (3-point)	100 – 240 V AC	10 Nm	–
Z45	NM24A	1-wire-control 2-wire-control (3-point)	24 V AC/DC	10 Nm	–
Z47	NM230A	1-wire-control 2-wire-control (3-point)	100 – 240 V AC	10 Nm	S2A
Z49	NM24A	1-wire-control 2-wire-control (3-point)	24 V AC/DC	10 Nm	S2A

Minimum torque of multileaf damper has to be considered when selecting the actuator.

Open/close actuators, fast-running

Order code detail	Description	Function	Supply voltage	Torque	Auxiliary switch
ZS21	SMQ24A	1-wire-control	24 V AC/DC	16 Nm	–
ZS22	SMQ24A	1-wire-control	24 V AC/DC	16 Nm	S2A

Only for nominal sizes with a minimum torque not exceeding 16 Nm.

Open/close actuators, spring return

Order code detail	Description	Function	Supply voltage	Torque	Auxiliary switch
ZF01	NF24A	Supply voltage on/off	24 V AC/DC	10 Nm	–
ZF02	NFA	Supply voltage on/off	24 – 240 V AC 24 – 125 V DC	10 Nm	–
ZF03	NF24A-S2	Supply voltage on/off	24 V AC/DC	10 Nm	integrated
ZF04	NFA-S2	Supply voltage on/off	24 – 240 V AC 24 – 125 V DC	10 Nm	integrated
ZF06	SF24A	Supply voltage on/off	24 V AC/DC	20 Nm	–
ZF07	SFA	Supply voltage on/off	24 – 240 V AC 24 – 125 V DC	20 Nm	–
ZF08	SF24A-S2	Supply voltage on/off	24 V AC/DC	20 Nm	integrated
ZF09	SFA-S2	Supply voltage on/off	24 – 240 V AC 24 – 125 V DC	20 Nm	integrated
ZF11	EF24A	Supply voltage on/off	24 V AC/DC	30 Nm	–
ZF12	EF230A	Supply voltage on/off	100 – 240 V AC	30 Nm	–
ZF13	EF24A-S2	Supply voltage on/off	24 V AC/DC	30 Nm	integrated
ZF14	EF230A-S2	Supply voltage on/off	100 – 240 V AC	30 Nm	integrated

Minimum torque of multileaf damper has to be considered when selecting the actuator.

Modulating actuators

Order code detail	Description	Function	Supply voltage	Torque	Auxiliary switch
Z20	SM24A-SR	2 – 10 V DC	24 V AC/DC	20 Nm	–
Z21	GM24A-SR	2 – 10 V DC	24 V AC/DC	40 Nm	–
Z51	NM24A-SR	2 – 10 V DC	24 V AC/DC	10 Nm	–

Minimum torque of multileaf damper has to be considered when selecting the actuator.

Modulating actuators, spring return

Order code detail	Description	Function	Supply voltage	Torque	Auxiliary switch
ZF05	NF24A-SR	2 – 10 V DC	24 V AC/DC	10 Nm	–
ZF10	SF24A-SR	2 – 10 V DC	24 V AC/DC	20 Nm	–
ZF15	EF24A-SR	2 – 10 V DC	24 V AC/DC	30 Nm	–

Minimum torque of multileaf damper has to be considered when selecting the actuator.

Double acting pneumatic actuators, including explosion-proof actuators

Order code detail		Description	Damper blade safety function	Operating pressure	Torque at 6 bar	Limit switch	Solenoid valve
(1)	(2)						
Z60	Z60 EX	DR030	–	1.2 – 6 bar	35 Nm	–	
Z61	Z61 EX	DR030	power off to close/open	1.2 – 6 bar	35 Nm	–	24 V DC
Z62	Z62 EX	DR030	power off to close/open	1.2 – 6 bar	35 Nm	–	230 V AC
Z63	Z63 EX	DR030	–	1.2 – 6 bar	35 Nm	2	
Z64	Z64 EX	DR030	power off to close/open	1.2 – 6 bar	35 Nm	2	24 V DC
Z65	Z65 EX	DR030	power off to close/open	1.2 – 6 bar	35 Nm	2	230 V AC
Z66	Z66 EX	DR060	–	1.2 – 6 bar	70 Nm	–	
Z67	Z67 EX	DR060	power off to close/open	1.2 – 6 bar	70 Nm	–	24 V DC
Z68	Z68 EX	DR060	power off to close/open	1.2 – 6 bar	70 Nm	–	230 V AC
Z69	Z69 EX	DR060	–	1.2 – 6 bar	70 Nm	2	
Z70	Z70 EX	DR060	power off to close/open	1.2 – 6 bar	70 Nm	2	24 V DC
Z71	Z71 EX	DR060	power off to close/open	1.2 – 6 bar	70 Nm	2	230 V AC

(1) Standard

(2) Explosion-proof (only with brass or stainless steel bearings)

Minimum torque, which depends on the nominal size of multileaf damper, and the operating pressure have to be considered when selecting the actuator.

Single acting pneumatic actuators, including explosion-proof actuators

Order code detail		Description	Damper blade safety function	Operating pressure	Torque at 6 bar	Limit switch	Solenoid valve
(1)	(2)						
Z72	Z72 EX	SC060 SO060	pressure off to close/open	6 bar	30 Nm	–	–
Z73	Z73 EX	SC060 SO060	power off and pressure off to close/open	6 bar	30 Nm	–	24 V DC
Z74	Z74 EX	SC060 SO060	power off and pressure off to close/open	6 bar	30 Nm	–	230 V AC
Z75	Z75 EX	SC060 SO060	pressure off to close/open	6 bar	30 Nm	2	–
Z76	Z76 EX	SC060 SO060	power off and pressure off to close/open	6 bar	30 Nm	2	24 V DC
Z77	Z77 EX	SC060 SO060	power off and pressure off to close/open	6 bar	30 Nm	2	230 V AC

(1) Standard

(2) Explosion-proof (only with brass or stainless steel bearings)

Explosion-proof open/close actuators, spring return actuators

Order code detail	Description	Function	Supply voltage	Torque	Auxiliary switch
Z1EX	ExMax15-SF	2-wire-control (3-point)	24 – 240 V AC/DC	15 Nm	integrated
Z3EX	ExMax30-SF	2-wire-control (3-point)	24 – 240 V AC/DC	30 Nm	integrated

Only with brass or stainless steel bearings

Z1EX: Only for nominal sizes with a minimum torque up to 15 Nm.

Product details

- Constructions with flange holes (-G) do not have corner holes
- Drive shafts (special accessory) upon request

Multileaf dampers made of steel or stainless steel, corner holes

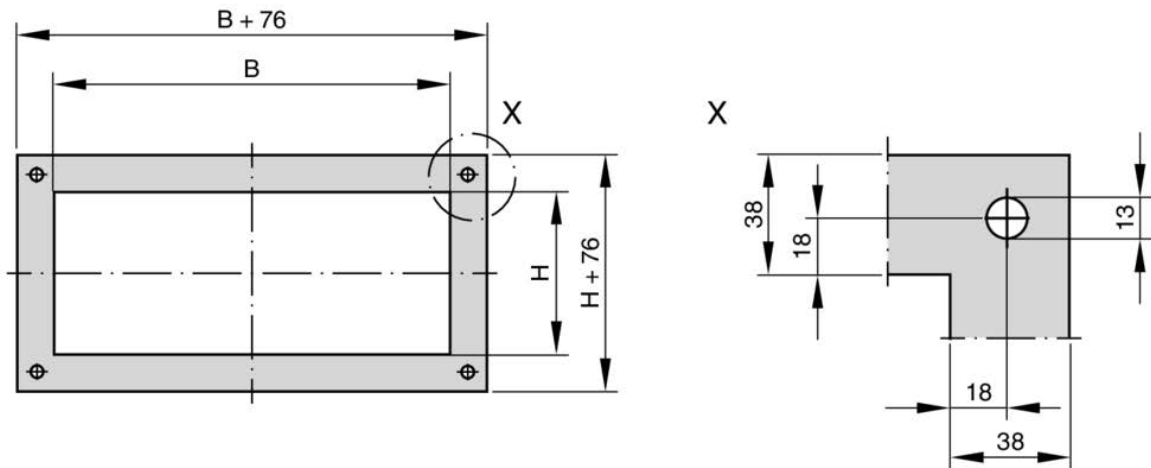

Multileaf dampers made of steel or stainless steel, flange holes

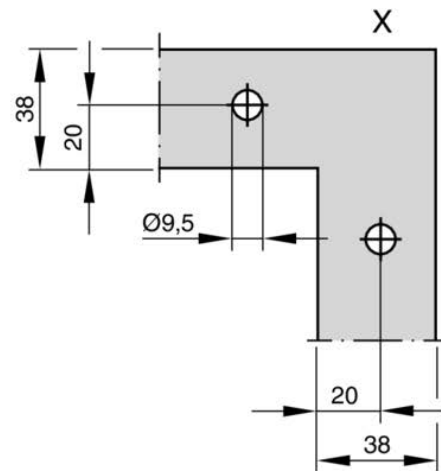
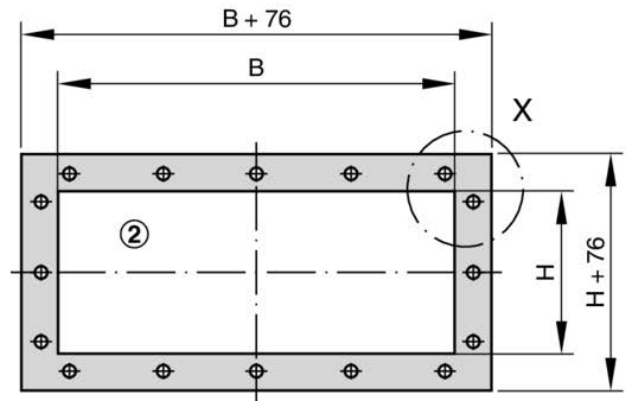
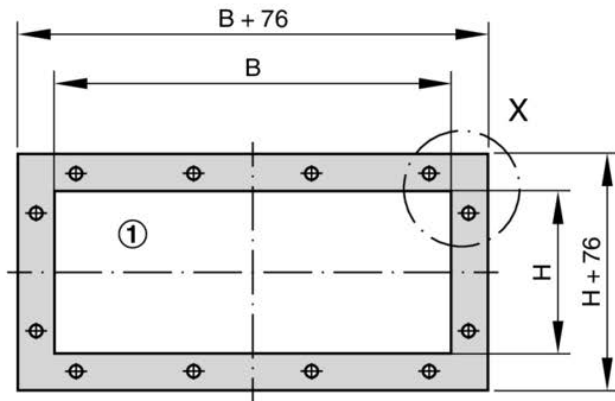

- ① Even number of holes (hole pitch = 250 mm)
- ② Uneven number of holes (hole pitch = 250 mm)

Steel or stainless steel multileaf dampers, width, no. of flange holes per side

B	Number of holes n
200 – 287	1
288 – 537	2
538 – 787	3
788 – 1037	4
1038 – 1287	5
1288 – 1537	6
1538 – 1787	7
1788 – 2000	8

Steel or stainless steel multileaf dampers, height, no. of flange holes per side

H	Number of holes n
180 – 211	1
212 – 461	2
462 – 711	3
712 – 961	4
962 – 1211	5
1212 – 1461	6
1462 – 1711	7
1712 – 1961	8
1962 – 1995	9

JZ-LL, JZ-HL, JZ-LL-A2, drive shafts

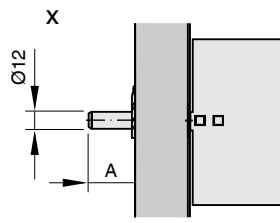
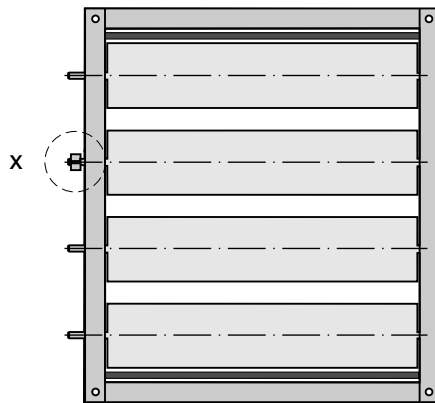

①

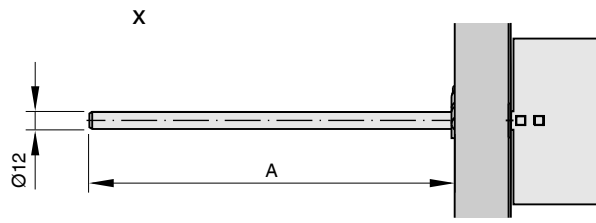

②

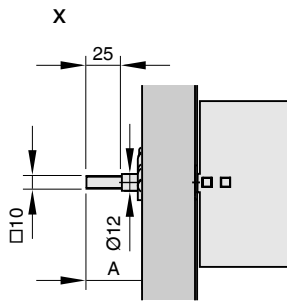

③

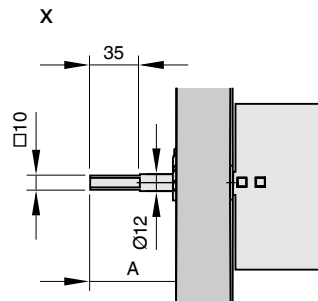

④

- ① Standard shaft
- ② ZS99 – extended spindle
- ③ ZS991 – square shaft 10 mm
- ④ ZS992 – square shaft 10 mm

Shaft end projection A [mm]

Drive shaft	Multileaf damper		
	JZ-LL	JZ-LL-A2	JZ-HL
① Standard	30	26	30
② Extended	250	180	250
③ Square 10 mm	37	37	37
④ Square 10 mm	70	–	60

The extended spindle ZS99, ZS991, ZS992 is designed in duplicate for blade torque > 10 Nm and mounted on blades 2 and 4 (only for type JZ-LL (galvanised steel)).

Installation details

Installation and commissioning

- Only with horizontal blades
- With or without installation subframe
- Torsion-free installation
- For widths exceeding 2000 mm or heights exceeding 1995 mm, install two multileaf dampers side by side or one above the other
- Only for installation in internal spaces

Wall installation without installation subframe

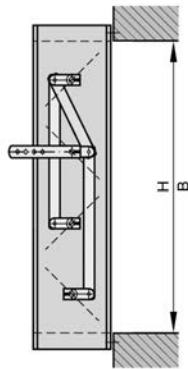

Duct installation

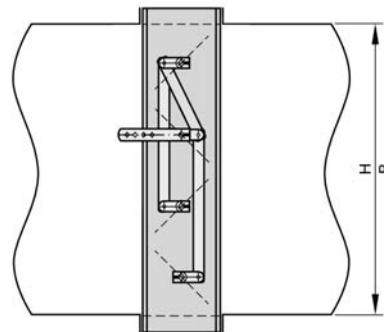

Width subdivided

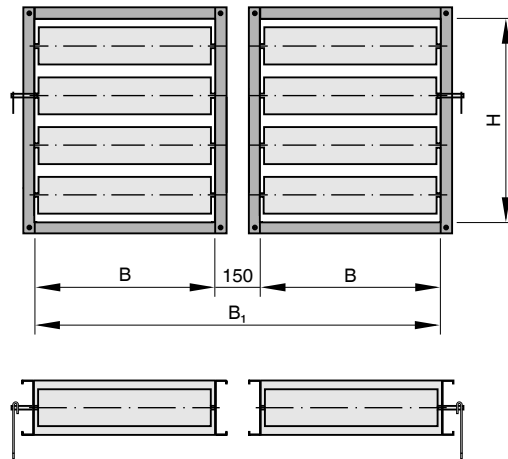

$$B_1 = 2 B + 150$$

Width subdivided, width [mm]

B_1	B
2550	1200
2950	1400
3350	1600
3750	1800
4150	2000

Height subdivided

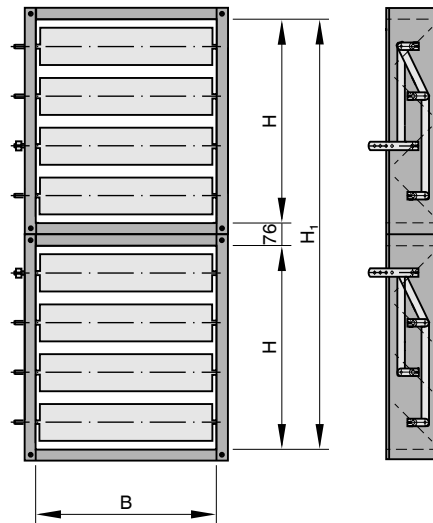

$$H_1 = 2 H + 76$$

Height subdivided, height

H_1	H
2086	1005
2416	1170
2746	1335
3076	1500
3406	1665
3736	1830
4066	1995

Nomenclature

B [mm]

Duct width

H [mm]

Duct height

Lengths

All lengths are given in millimetres [mm] unless stated otherwise

n []

Number of flange screw holes

m [kg]

Weight

L_{WA} [dB(A)]

A-weighted sound power level of air-regenerated noise for the multileaf damper

α [kPa]

Damper blade position, 0°: OPEN, 90°: CLOSED

A [m²]

Upstream cross section

v [m/s]

Airflow velocity based on the upstream cross section (B × H)

q_v [m³/h]; [l/s]

Volume flow rate

Δp_t [Pa]

Differential pressure

Δp_{max t} [Pa]

Maximum differential pressure