



Circular diffuser faces with circular plenum box



Square diffuser face with square plenum box



Circular face style with circular plenum box and top entry spigot



Circular diffuser face with white air control blades

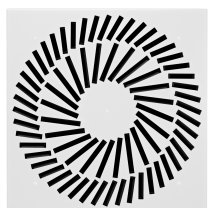

Air terminal device up to size 825

Ceiling diffusers

VDW

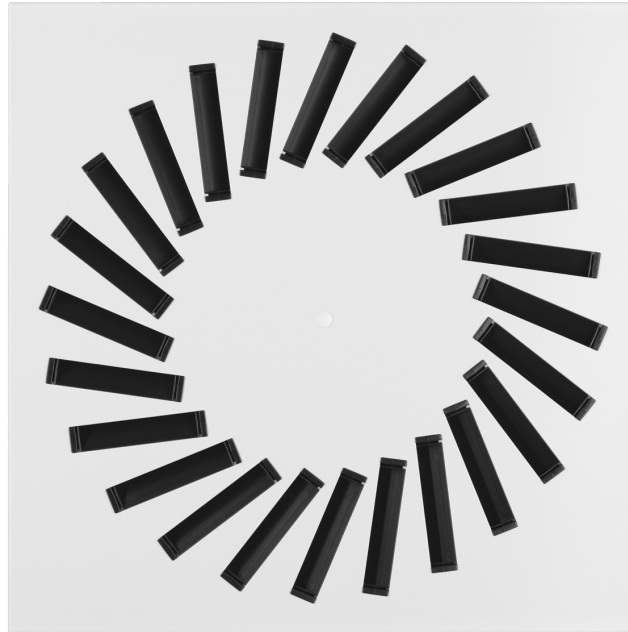

With low sound power level for comfort zones, with individually manually adjustable air control blades

Circular and square ceiling swirl diffusers for high room air change rates

- Nominal sizes 300, 400, 500, 600, 625, 825
- Volume flow rate range 7 – 470 l/s or 25 – 1692 m³/h
- Diffuser face made of galvanised sheet steel, powder-coated
- For variable and constant volume flows
- For all types of ceiling systems, and with an extended border also suitable for freely suspended installation
- High induction results in a rapid reduction of the temperature difference and airflow velocity
- Very high room air change rate due to row arrangement with a minimum pitch distance of 0.9 m
- Ideal for comfort zones
- Circular diffuser faces can be easily mounted without tools in a circular plenum box with horizontal spigot

Optional equipment and accessories

- Exposed diffuser face available in RAL CLASSIC colours, air control blades in black or white
- Horizontal or vertical duct connection
- Square plenum box with cord-operated damper unit and pressure tap

General information	2	Variants	10
Function	4	Dimensions	19
Technical data	6	Air patterns	23
Quick sizing	6	Product details	26
Specification text	8	Nomenclature	31
Order code	9		

General information

Application

- Ceiling swirl diffusers are used as supply air or extract air diffusers for comfort zones
- Attractive design element for building owners and architects with demanding aesthetic requirements
- Horizontal swirling supply air discharge for mixed flow ventilation
- The efficient swirl creates high induction levels, thereby rapidly reducing the temperature difference and airflow velocity (supply air variant)
- For variable and constant volume flows
- For supply air to room air temperature differences from -12 – +10 K
- For room heights up to 4 m (lower edge of suspended ceiling)
- For all types of ceiling systems
- With an extended border also suitable for freely suspended installation (supply air variant)

Special features

- High induction results in a rapid reduction of the supply air to room air temperature difference and airflow velocity
- For all types of ceiling systems, and with an extended border also suitable for freely suspended installation
- Horizontal or vertical duct connection
- Very high room air change rate possible thanks to row arrangement with a minimum pitch distance of 0.9 m

Nominal sizes

- 300 × 8, 400 × 16, 500 × 24, 600 × 24, 600 × 48, 625 × 24, 625 × 54, 825 × 72

Variants

- VDW-Q: Square diffuser face
- VDW-R: Circular diffuser face
- VDW-*-Z: Supply air
- VDW-*-A: Extract air

Connection on

- H: Horizontal duct connection
- V: Vertical duct connection

Accessories

Lip seal

- For circular plenum boxes with horizontal connection spigot, the lip seal is only available in combination with the flow adjustment damper. Otherwise, it can always be selected optionally.

Attachments

- M: Damper element for volume flow rate balancing
- MN: Pressure tap and cord-operated damper unit for volume flow rate balancing with the diffuser face in place (only possible with square plenum box)

Construction features

- Spigot suitable for circular ducts to EN 1506 or EN 13180
- Square plenum boxes and plenum boxes with vertical connection
 - With spigot made of galvanised sheet steel
 - Groove only available if lip density characteristic has been selected

Circular plenum boxes with horizontal spigot for nominal sizes 250, 400L, 400H and 600

- Spigot made of black ABS
- Spigots are fitted with a groove for a lip seal
- Retrofitting of the lip seal is possible at a later stage
- Damper blade and lip seal (optional) are factory fitted
- Plenum box for supply air, with an optimised equalising element that ensures a uniform airflow through the diffuser face
- Simple installation of the diffuser face due to central fixing screw with cap
- Plenum box for supply air, with an optimised equalising element that ensures a uniform airflow through the diffuser face
- Simple installation of the diffuser face due to central fixing screw with decorative cap

Materials and surfaces

- Grille face made of galvanised sheet steel
- Q; R: Plenum box made of galvanised sheet steel including galvanised sheet steel cross bar to support the diffuser face
- Plenum boxes with vertical connection and square plenum boxes with horizontal connection: for supply air always with galvanised perforated plate for air distribution
- Circular plenum boxes with horizontal spigot: Equipped as a plenum box for supply air with an equalising element made of polyester
- Square plenum boxes and plenum boxes with vertical spigot: Spigot made of galvanised sheet steel
- Circular plenum boxes with horizontal spigot: Spigot made of black ABS, according to UL94, V0 flame retardant
- Air control blades made of plastic, UL 94, V-0, flame retardant
- Lip seal made of Evoprene
- Diffuser face coated RAL 9010, pure white
- P1: Powder-coated, RAL Classic colour
- Air control blades for supply air similar to RAL 9005, black; extract air variant without air control blades
- Q11: Air control blades for extract air similar to RAL 9005, black
- Q21: Air control blades for supply air and extract air similar to RAL 9010, white

Standards and guidelines

- Sound power level of the air-regenerated noise measured according to EN ISO 5135



Maintenance

- Low maintenance as construction and materials are not subject to wear
- Inspection and cleaning to VDI 6022

Function

Ceiling swirl diffusers in air conditioning systems create a swirl to supply air to rooms. The resulting airflow induces high levels of room air, thereby rapidly reducing the airflow velocity and the temperature difference between supply air and room air. Ceiling swirl diffusers allow for large volume flow rates. The result is a mixed flow ventilation in comfort zones, with good overall room ventilation, creating only very little turbulence in the occupied zone.

Type VDW ceiling swirl diffusers have adjustable air control blades. The airflow direction can be adjusted to meet various local requirements. Horizontal air distribution consists of one-

way, two-way or omni-directional flow. Vertical air discharge is possible but only for heating. The supply air to room air temperature difference may range from -12 to +10 K. A damper blade (optional) simplifies volume flow rate balancing for commissioning. Pressure tap and cord-operated damper blade (optional) allow for volume flow rate balancing with the diffuser face in place.

To give rooms an aesthetic, uniform look, Type VDW diffusers may also be used for extract air. Air control blades are not required for extract air applications.

Schematic illustration of VDW-Q with square plenum box

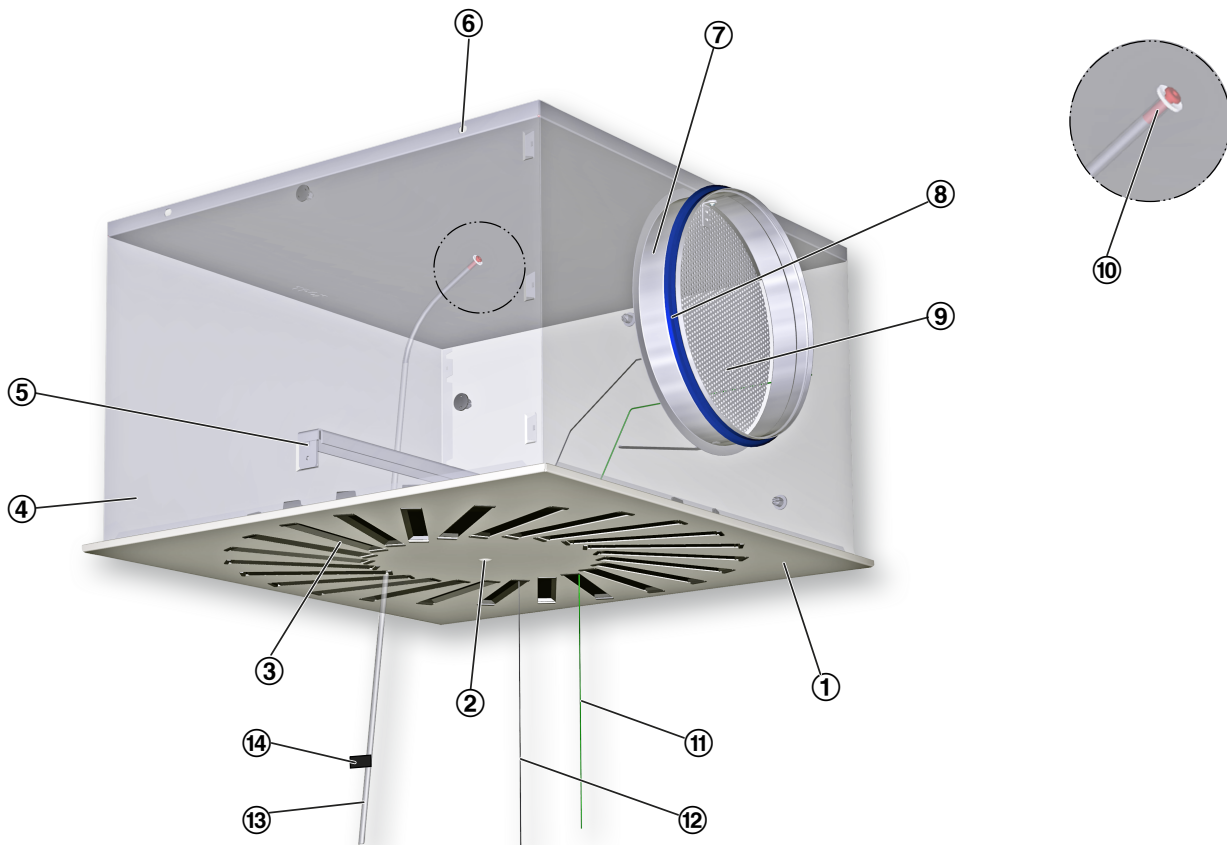

- ① Diffuser face
- ② Central fixing screw
- ③ Adjustable air control blade
- ④ Plenum box
- ⑤ Cross bar
- ⑥ Suspension hole
- ⑦ Spigot

- Optional
- ⑧ Lip seal
 - ⑨ Damper blade for volume flow rate balancing
 - ⑩ Pressure tap
 - ⑪ Green cord for closing the damper blade
 - ⑫ White cord for opening the damper blade
 - ⑬ Measuring tube
 - ⑭ Text label indicating plenum box variant

Schematic illustration of VDW-R with circular plenum box and side entry spigot

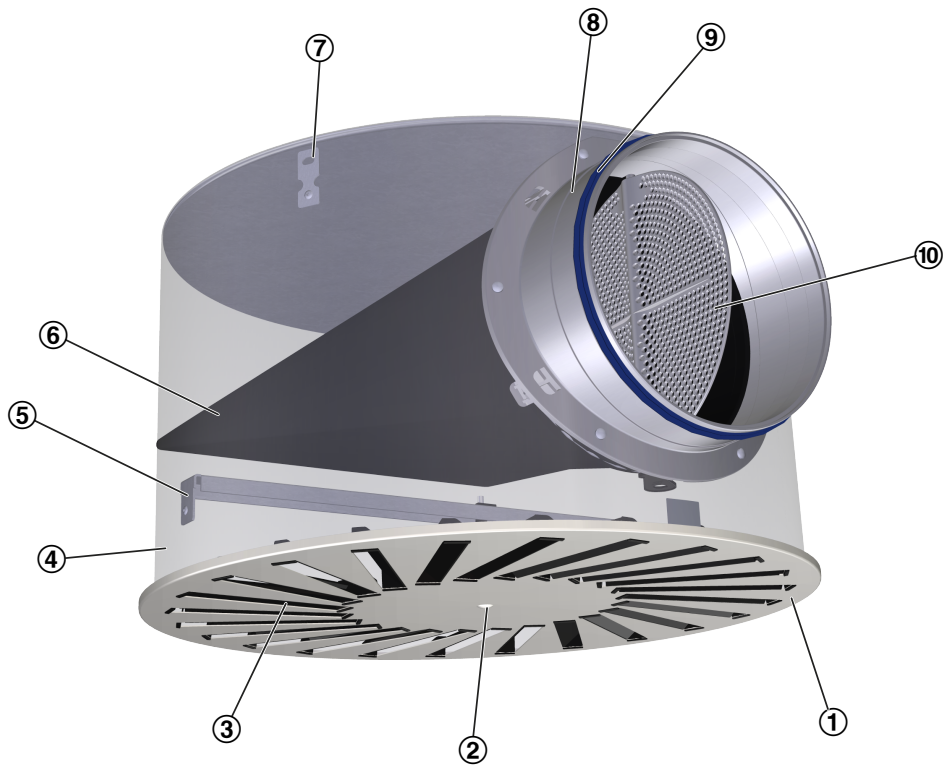

- ① Diffuser face
- ② Central fixing screw
- ③ Adjustable air control blade
- ④ Plenum box
- ⑤ Cross bar
- ⑥ Equalising element
- ⑦ Suspension bracket
- ⑧ Spigot
- Optional
- ⑨ Lip seal
- ⑩ Damper blade for volume flow rate balancing

Technical data

Nominal sizes	300, 400, 500, 600, 625, 825 mm
Minimum volume flow rate, with $\Delta t_z = -6$ K	7 – 99 l/s or 25 – 357 m ³ /h
Maximum volume flow rate, with LWA \approx 50 dB(A)	80 – 470 l/s or 288 – 1692 m ³ /h
Supply air to room air temperature difference	-12 – 10 K

Quick sizing

Quick sizing tables provide a good overview of the volume flow rates and corresponding sound power levels and differential pressures.

The minimum volume flow rates apply to a supply air to room air temperature difference of –6 K.

The maximum volume flow rates apply to a sound power level of approx. 50 dB (A) with damper blade position 0°.

Exact values for all parameters can be determined with our Easy Product Finder design program.

VDW^{-z}-Z-H (supply air), sound power level and total differential pressure

NS	qv [l/s]	qv [m ³ /h]	0°		45°		90°	
			Δp_t [Pa]	LWA [dB(A)]	Δp_t [Pa]	LWA [dB(A)]	Δp_t [Pa]	LWA [dB(A)]
300 × 8	7	26	1	<15	1	<15	1	<15
300 × 8	35	108	12	20	14	20	22	21
300 × 8	60	198	41	38	46	38	74	39
300 × 8	85	288	87	50	98	51	157	52
400 × 16	13	46	1	<15	1	<15	1	<15
400 × 16	60	198	11	21	13	20	26	20
400 × 16	100	360	38	39	44	40	85	40
500 × 24	70	252	10	18	14	21	35	24
500 × 24	125	450	31	36	45	40	112	43
500 × 24	175	648	65	50	94	54	233	59
600 × 24, 625 × 24	28	102	1	<15	1	<15	2	<15
600 × 24, 625 × 24	105	360	10	22	13	23	30	26
600 × 24, 625 × 24	165	612	28	38	38	40	87	43
600 × 24, 625 × 24	260	864	56	50	75	54	174	57
600 × 48	40	145	1	<15	2	<15	4	<15
600 × 48	130	432	10	22	16	26	39	31
600 × 48	210	720	27	38	43	44	109	48
600 × 48	305	1008	53	50	85	58	214	63
625 × 54	140	468	10	23	16	26	42	33
625 × 54	225	756	27	38	42	44	109	49
625 × 54	310	1044	51	50	81	59	208	62
825 × 72	99	357	3	<15	4	<15	10	<15
825 × 72	225	756	11	25	17	27	46	28
825 × 72	470	1692	47	50	70	55	193	54

0°, 45°, 90°: Damper blade position

VDW*-Z-V (supply air), sound power level and total differential pressure

NS	qv [l/s]	qv [m³/h]	0°		45°		90°	
			Δpt [Pa]	LWA [dB(A)]	Δpt [Pa]	LWA [dB(A)]	Δpt [Pa]	LWA [dB(A)]
300 × 8	7	26	1	<15	1	<15	1	<15
300 × 8	30	108	12	20	14	20	22	21
300 × 8	55	198	41	38	46	38	74	39
300 × 8	80	288	87	50	98	51	157	52
400 × 16	13	46	1	<15	1	<15	1	<15
400 × 16	55	198	11	21	13	20	26	20
400 × 16	100	360	38	39	44	40	85	40
400 × 16	140	504	74	50	86	51	167	52
500 × 24	19	70	1	<15	1	<15	3	<15
500 × 24	70	252	10	18	14	21	35	24
500 × 24	125	450	31	36	45	40	112	43
500 × 24	180	648	65	50	94	54	233	59
600 × 24, 625 × 24	28	102	1	<15	1	<15	2	<15
600 × 24, 625 × 24	100	360	10	22	13	23	30	26
600 × 24, 625 × 24	170	612	28	38	38	40	87	43
600 × 24, 625 × 24	240	864	56	50	75	54	174	57
600 × 48	40	145	1	<15	2	<15	4	<15
600 × 48	120	432	10	22	16	26	39	31
600 × 48	200	720	27	38	43	44	109	48
600 × 48	280	1008	53	50	85	58	214	63
625 × 54	52	186	2	<15	3	<15	7	<15
625 × 54	130	468	10	23	16	26	42	33
625 × 54	210	756	27	38	42	44	109	49
625 × 54	290	1044	51	50	81	59	208	62
825 × 72	99	357	3	<15	4	<15	10	<15
825 × 72	210	756	11	25	17	27	46	28
825 × 72	320	1152	26	39	39	42	107	42
825 × 72	430	1692	47	50	70	55	193	54

0°, 45°, 90°: Damper blade position

Specification text

This specification text describes the general characteristics of the product. Texts for variants can be generated with our Easy Product Finder design program.

Specification text

Ceiling swirl diffusers with square or circular diffuser face. Supply air and extract air variants for comfort zones, for a maximum air change rate of 35 per hour. Diffuser face with individually manually adjustable air control blades for horizontal swirling supply air discharge creating high induction levels. For installation into all types of suspended ceilings. Ready-to-install component consisting of the diffuser face with radially arranged, individually adjustable black or white set of air control blades and a plenum box, which is also square in the case of square faceplates (-Q) and round in the case of rounded faceplates (-R). The plenum box has an equalising element for supply air. The plenum box always includes a horizontally or vertically arranged spigot, cross bar and drilled holes or suspension lugs for suspension. The diffuser face is fixed to the cross bar with a central screw, concealed by a decorative cap. Spigot suitable for ducts to EN 1506 or EN 13180. Sound power level of the air-regenerated noise measured according to EN ISO 5135.

Special features

- High induction results in a rapid reduction of the supply air to room air temperature difference and airflow velocity
- For all types of ceiling systems, and with an extended border also suitable for freely suspended installation
- Horizontal or vertical duct connection
- Very high room air change rate possible thanks to row arrangement with a minimum pitch distance of 0.9 m

Materials and surfaces

- Grille face made of galvanised sheet steel
- Q; R: Plenum box made of galvanised sheet steel including galvanised sheet steel cross bar to support the diffuser face
- Plenum boxes with vertical connection and square plenum boxes with horizontal connection: for supply air always with galvanised perforated plate for air distribution
- Circular plenum boxes with horizontal spigot: Equipped as a plenum box for supply air with an equalising element made of polyester
- Square plenum boxes and plenum boxes with vertical spigot: Spigot made of galvanised sheet steel
- Circular plenum boxes with horizontal spigot: Spigot made of black ABS, according to UL94, V0 flame retardant
- Air control blades made of plastic, UL 94, V-0, flame retardant
- Lip seal made of Evoprene
- Diffuser face coated RAL 9010, pure white
- P1: Powder-coated, RAL Classic colour
- Air control blades for supply air similar to RAL 9005, black; extract air variant without air control blades
- Q11: Air control blades for extract air similar to RAL 9005, black
- Q21: Air control blades for supply air and extract air similar to RAL 9010, white

Technical data

- 300 × 8, 400 × 16, 500 × 24, 600 × 24, 600 × 48, 625 × 24, 625 × 54, 825 × 72
- Minimum volume flow rate, for $\Delta tZ = -6$ K: 7 – 99 l/s or 26 – 357 m³/h
- Maximum volume flow rate, at LWA \cong 50 dB(A): 85 – 470 l/s or 306 – 1692 m³/h
- Supply air to room air temperature difference: -12 to +10 K

Order code

VDW - Q - Z - H - M - L / 500 × 24 / Q21 / P1 - RAL ...
 | | | | | | | | |
 1 2 3 4 5 6 7 8 9

1 Type

VDW Swirl diffuser

600 × 24

600 × 48

625 × 24

2 Construction style

R Circular

VDW-Q only

Q Square

625 × 54

825 × 72

3 System

Z Supply air

A extract air

8 Colour of air control blades

No entry required: supply air – black air control blades, extract air – no air control blades

Q11 Extract air – black air control blades

Q21 Supply air – white air control blades; extract air – white air control blades

4 Connection

H horizontal

V Vertical (the plenum box is always circular)

5 Damper blade for volume flow rate balancing

No entry required: Without damper unit

M With

MN With cords and pressure tap (only with square plenum box)

9 Exposed surface

No entry: powder-coated RAL 9010, pure white

P1 Powder-coated, specify RAL CLASSIC colour

6 Accessories

No entry required: Without accessories

L with lip seal

Gloss level

RAL 9010 GU50

RAL 9006 GU30

All other RAL colours GU70

7 Nominal size [mm]

300 × 8

400 × 16

500 × 24

Note: Circular plenum boxes with horizontal spigot are only available without damper unit and lip seal or with damper unit and lip seal. Features 2 and 4 define the plenum box geometry.

Order example: VDW-Q-Z-H-MN-L/600×24/Q21/P1-RAL 9006

Style	Square
Air conditioning system	Supply air
Connection on	horizontal
Damper unit for volume flow rate balancing	With cord and pressure tap
Accessories	Lip seal
Nominal size	600 × 24
Colour of air control elements	White
Exposed surface	RAL 9006, white aluminium, GU30

Order example: VDW-R-Z-H-/400×16

Style	Circular
Air conditioning system	Supply air
Connection on	horizontal
Damper unit for volume flow rate balancing	None
Accessories	None
Nominal size	400 × 16
Colour of air control elements	Black
Exposed surface	RAL 9010, pure white, GU50

Variants

VDW-Q-Z/300×8



Nominal sizes

□300×8

VDW-Q-Z/400×16

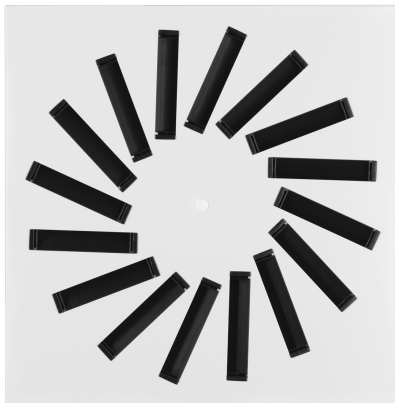

Nominal sizes

□400×16

VDW-Q-Z/500×24

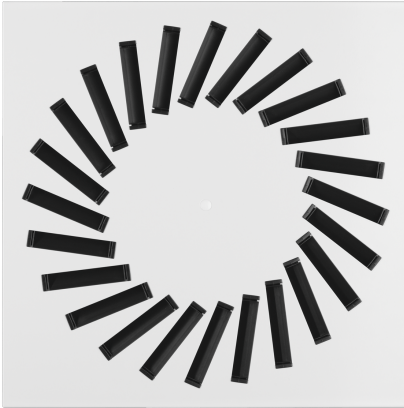

Nominal sizes

□500×24

VDW-Q-Z/600×24

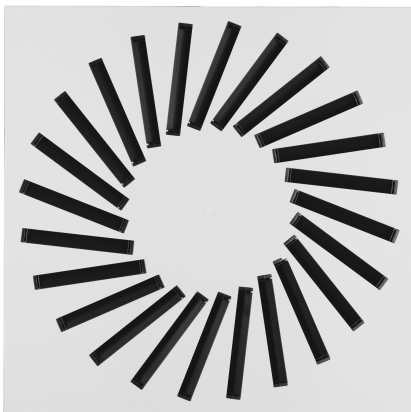

Nominal sizes

□600×24

VDW-Q-Z/600×48

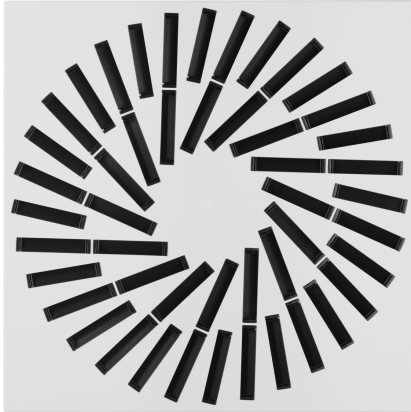

Nominal sizes

□600×48

VDW-Q-Z/625×24

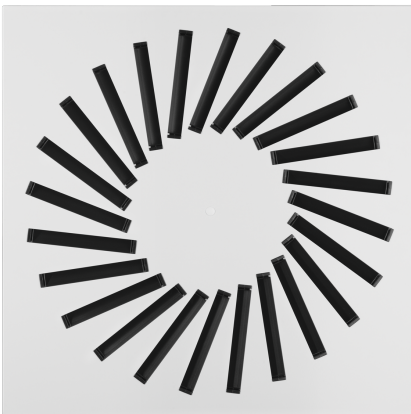

Nominal sizes

□625×24

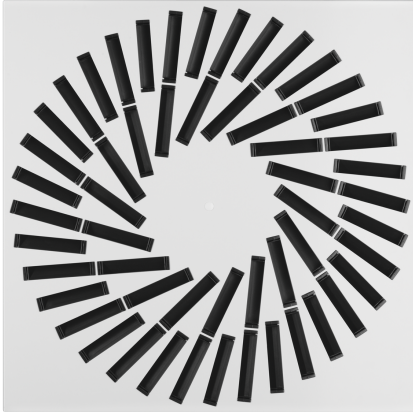
VDW-Q-Z/625×54**Nominal sizes**

□625×54

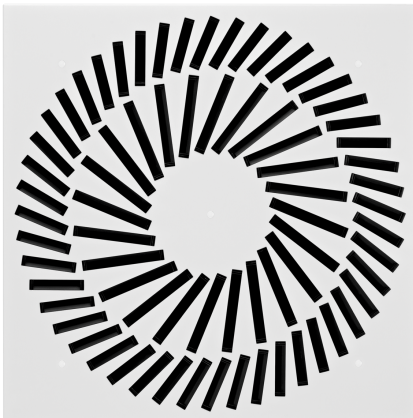
VDW-Q-Z/825×72**Nominal sizes**

□825×72

VDW-Q-*-H**Variants**

- Ceiling swirl diffuser with square diffuser face
- With square plenum box for horizontal duct connection

Nominal sizes

- 300 × 8, 400 × 16, 500 × 24, 600 × 24, 600 × 48, 625 × 24, 625 × 54, 825 × 72

Accessories

- Square diffuser face
- Plenum box for horizontal duct connection
- Square opening to accommodate the diffuser face
- Equalising element that ensures a uniform airflow through the diffuser face (supply air variant)
- Simple installation of the diffuser face due to central fixing screw with decorative cap
- Damper blade for volume flow rate balancing (optional)
- Pressure tap and cord-operated damper blade for volume flow rate balancing (optional)
- Lip seal (optional)

Construction features

- Spigot suitable for circular ducts to EN 1506 or EN 13180
 - Spigot with groove for lip seal (if accessory lip seal has been ordered)
-

VDW-Q*-V**Variants**

- Ceiling swirl diffuser with square diffuser face
- With square plenum box for vertical duct connection

Nominal sizes

- 300 × 8, 400 × 16, 500 × 24, 600 × 24, 600 × 48, 625 × 24, 625 × 54, 825 × 72

Accessories

- Square diffuser face
- Plenum box for vertical duct connection
- Circular opening to accommodate the diffuser face
- Equalising element that ensures a uniform airflow through the diffuser face (supply air variant)
- Simple installation of the diffuser face due to central fixing screw with decorative cap
- Damper blade for volume flow rate balancing (optional)
- Lip seal (optional)

Construction features

- Spigot suitable for circular ducts to EN 1506 or EN 13180
- Spigot with groove for lip seal (if accessory lip seal has been ordered)

VDW-R-Z/300×8



Nominal sizes

Ø300×8

VDW-R-Z/400×16

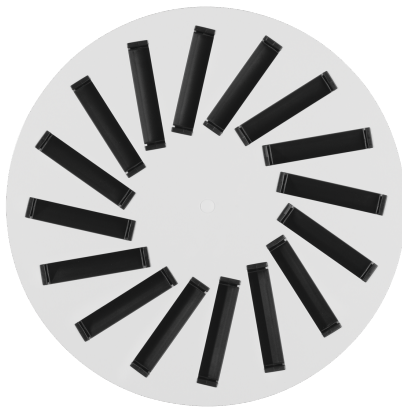

Nominal sizes

Ø400×16

VDW-R-Z/500×24

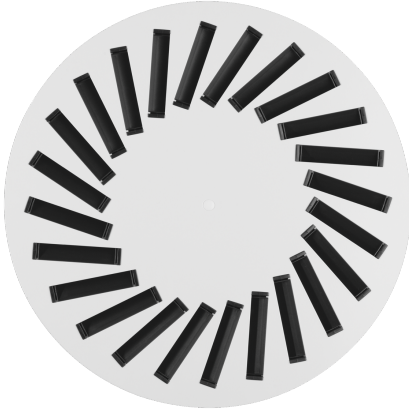

Nominal sizes

Ø500×24

VDW-R-Z/600×24

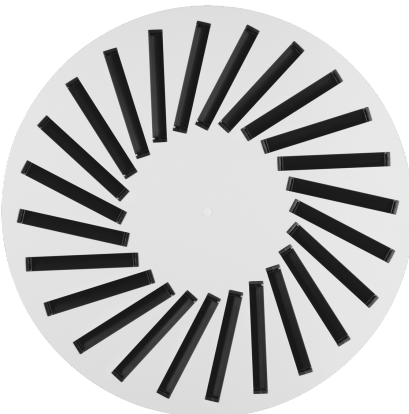

Nominal sizes

Ø600×24

VDW-R-Z/600×48

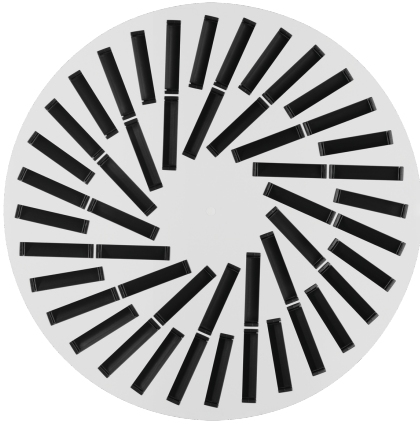
**Nominal sizes**

Ø600×48

VDW-R-Z/625×24

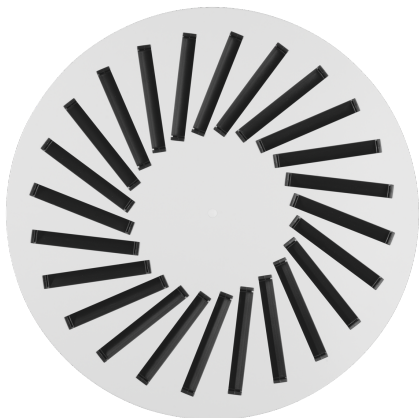
**Nominal sizes**

Ø625×24

VDW-R-*-H**Variants**

- Ceiling swirl diffuser with circular diffuser face
- With circular plenum box for horizontal duct connection

Nominal sizes

- 300 × 8, 400 × 16, 500 × 24, 600 × 24, 600 × 48, 625 × 24

Accessories

- Circular diffuser face
- Plenum box for horizontal duct connection
- Equalising element that ensures a uniform airflow through the diffuser face (supply air variant)
- Simple installation of the diffuser face due to central fixing screw with decorative cap
- Damper unit for volume flow rate balancing and lip seal, optional

Construction features

- Spigot suitable for circular ducts to EN 1506 or EN 13180
 - Spigot made of plastic (ABS)
-

VDW-R-*-V**Variants**

- Ceiling swirl diffuser with circular diffuser face
- With circular plenum box for vertical duct connection

Nominal sizes

- 300 × 8, 400 × 16, 500 × 24, 600 × 24, 600 × 48, 625 × 24

Accessories

- Circular diffuser face
- Plenum box for vertical duct connection
- Circular opening to accommodate the diffuser face
- Equalising element that ensures a uniform airflow through the diffuser face (supply air variant)
- Simple installation of the diffuser face due to central fixing screw with decorative cap
- Damper blade for volume flow rate balancing (optional)
- Lip seal (optional)

Construction features

- Spigot suitable for circular ducts to EN 1506 or EN 13180
- Spigot with groove for lip seal (if accessory lip seal has been ordered)

Dimensions

Square diffuser face with plenum box for horizontal duct connection

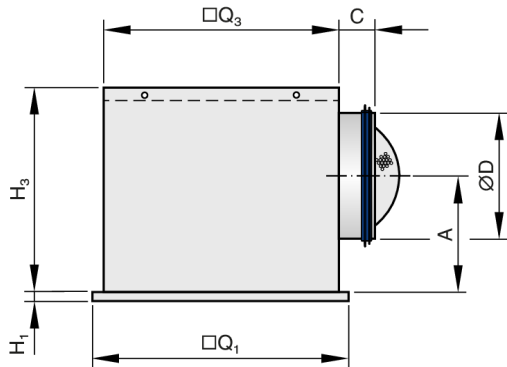

VDW-Q*-H

NS	$\square Q_1$	H_1	$\square Q_3$	H_3	$\varnothing D$	A	C	①	m kg
300 × 8	310	8	290	250	158	139	50	AK-Uni-001	3.7
400 × 16	398	8	372	295	198	164	50	AK-Uni-002	5.7
500 × 24	498	8	476	295	198	164	50	AK-Uni-003	7.8
600 × 24	598	8	567	345	248	199	48	AK-Uni-004	11.1
600 × 48	598	8	590	345	248	189	48	AK-Uni-005	11.4
625 × 24	623	8	567	345	248	199	48	AK-Uni-004	11.3
625 × 54	623	8	615	345	248	189	48	AK-Uni-006	12
825 × 72	825	8	806	410	313	222	50	AK-Uni-007	21.2

① Plenum box

Weights apply to the supply air variant

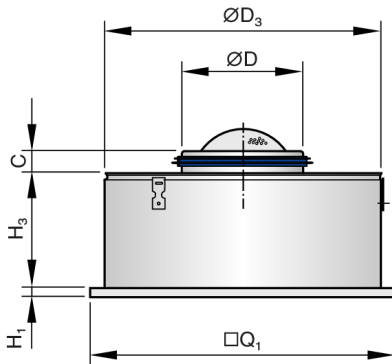
Square diffuser face with plenum box for vertical duct connection

VDW-Q*-V

NS	$\square Q_1$	H_1	$\varnothing D_3$	H_3	$\varnothing D$	C	m kg
300 × 8	310	8	275	200	158	50	2.7
400 × 16	398	8	364	200	198	50	4.2
500 × 24	498	8	462	200	198	50	6
600 × 24	598	8	559	200	248	48	8.4
600 × 48	598	8	575	300	248	48	9.6
625 × 24	623	8	559	200	248	48	8.6
625 × 54	623	8	600	300	248	48	10.3
825 × 72	825	8	796	300	313	50	16.2

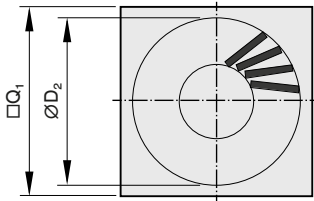
Weights apply to the supply air variant

Diffuser face VDW-Q

VDW-Q

NS	$\square Q_1$	$\varnothing D_2$	n	A_{eff} m ²
300 × 8	310	269	8	0.0070
400 × 16	398	352	16	0.0140
500 × 24	498	440	24	0.0210
600 × 24	598	546	24	0.0295
600 × 48	598	568	48	0.0390
625 × 24	623	546	24	0.0295
625 × 54	623	594	54	0.0470
825 × 72	825	773	72	0.0730

n = no. of air control blades

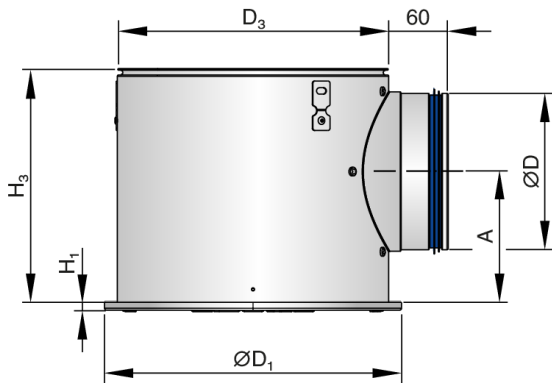
Circular diffuser face with circular plenum box for horizontal duct connection



VDW-R-*-H

NS	ØD ₁	H ₁	H ₃	ØD ₃	ØD	A	①	m
	kg							
300 × 8	273	8	243	274	158	139	AKR-01	2.1
400 × 16	362	8	290	363	198	166	AKR-02	3.3
500 × 24	460	8	290	461	198	166	AKR-03	4.5
600 × 24	573	8	344	574	248	195	AKR-05	6.4
600 × 48	573	8	344	574	248	195	AKR-05	6.7
625 × 24	573	8	344	574	248	195	AKR-05	6.6

Weights apply to the supply air variant

Circular diffuser face with plenum box for vertical duct connection

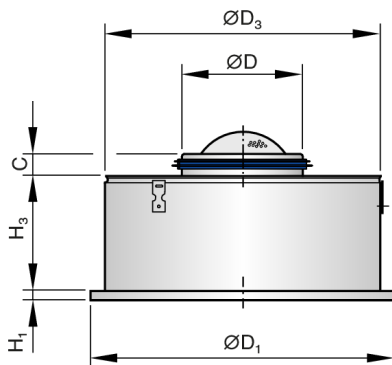

VDW-R-*-V

NS	ØD ₁	H ₁	ØD ₃	H ₃	ØD	C	m
	kg						
300 × 8	300	8	275	200	158	50	2.5
400 × 16	400	8	364	200	198	50	3.9
500 × 24	500	8	462	200	198	50	5.6
600 × 24	600	8	559	200	248	48	7.5
600 × 48	600	8	575	300	248	48	8.7
625 × 24	625	8	559	200	248	48	7.7

Weights apply to the supply air variant

Diffuser face VDW-R

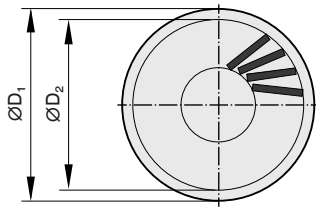

VDW-R

NS	$\varnothing D_1$	$\varnothing D_2$	n	A_{eff}
				m^2
300 × 8	300	269	8	0.0070
400 × 16	400	352	16	0.0140
500 × 24	500	440	24	0.0210
600 × 24	600	546	24	0.0295
600 × 48	600	568	48	0.0390
625 × 24	625	546	24	0.0295

n = no. of air control blades

Air patterns

Air control blades set to external swirl

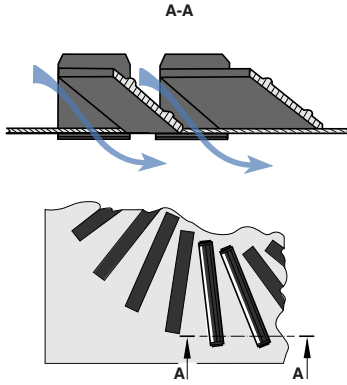

Air control blades set to internal swirl

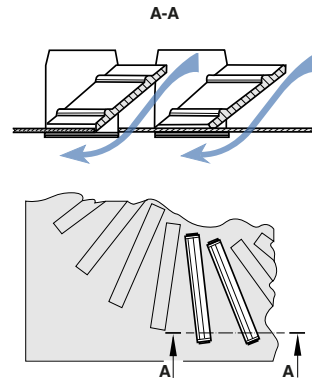

Horizontal omni directional air discharge

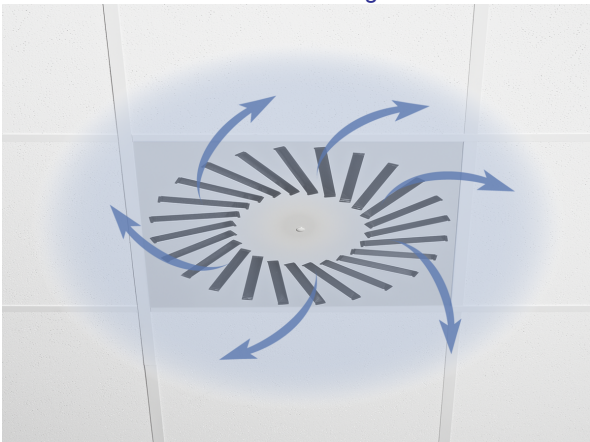

Setting of the air control elements

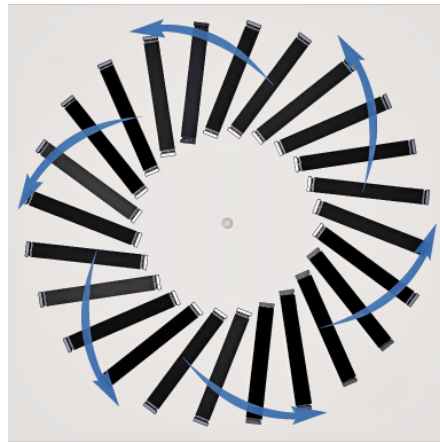

All air control blades set to external swirl

Setting of the air control elements

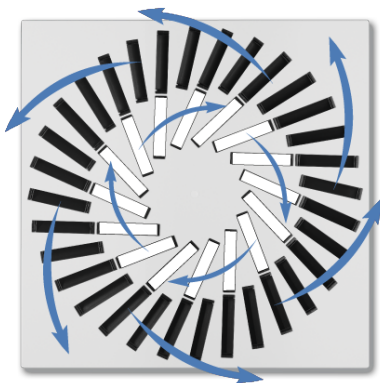

Horizontal one-way air discharge

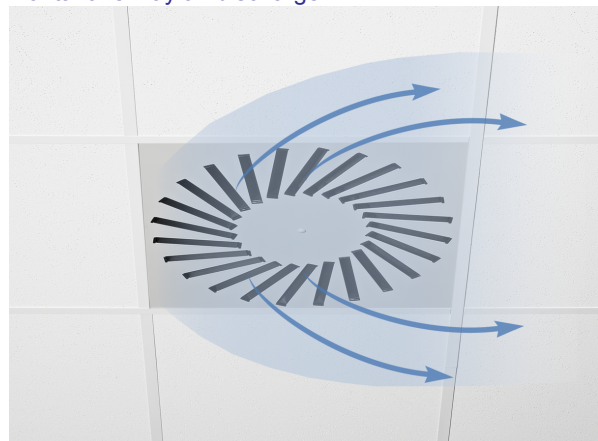

Outer air control blades set to external swirl, inner blades set to internal swirl

Setting of the air control elements

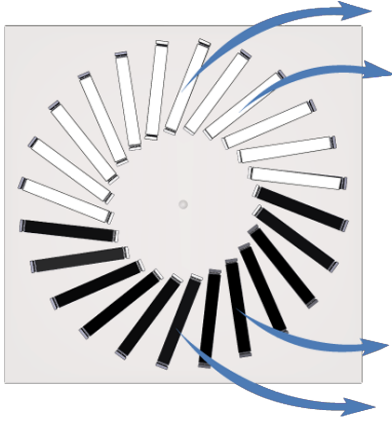

Horizontal two-way air discharge

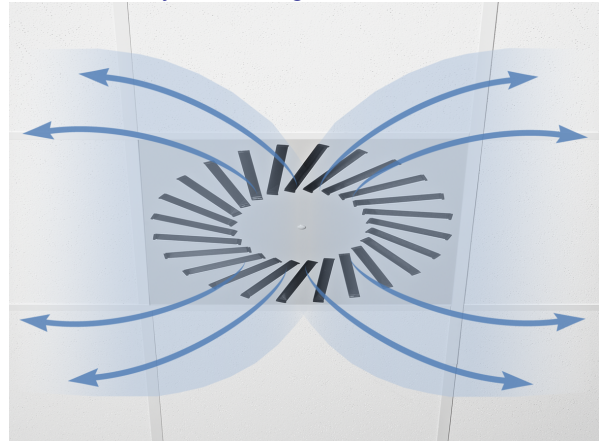

Air control blades set to internal and external swirl per half circle

Setting of the air control elements

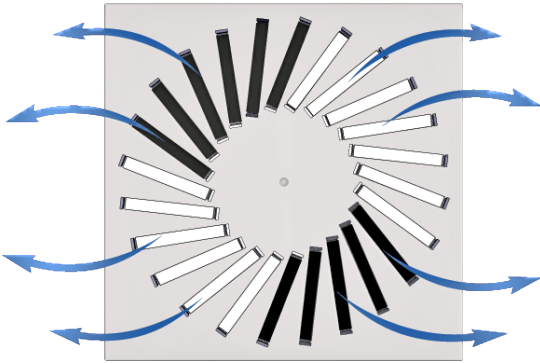

Air control blades set to internal and external swirl per quadrant

Air control blades set to vertical air discharge

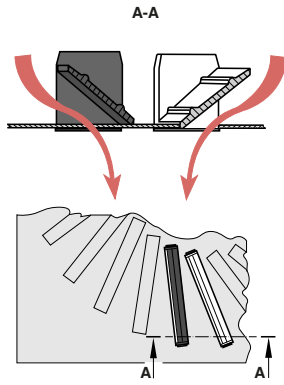

Vertical air discharge

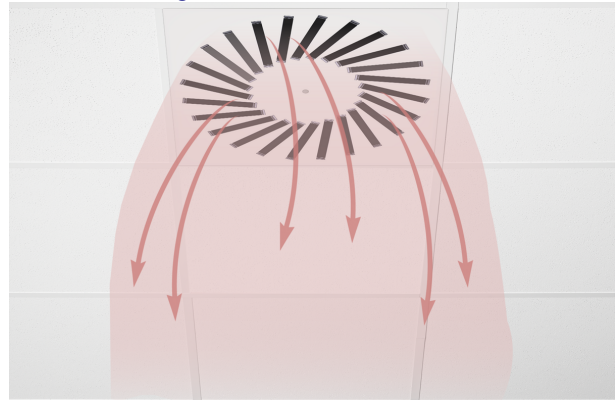

Setting of the air control elements



Air control blades set alternately to internal and external swirl

Product details

Installation in T-bar ceilings



VDW-Q with black air control blades

Installation in T-bar ceilings



VDW-Q with white air control blades

Installation in T-bar ceilings, arrangement in a row



Installation in continuous ceilings

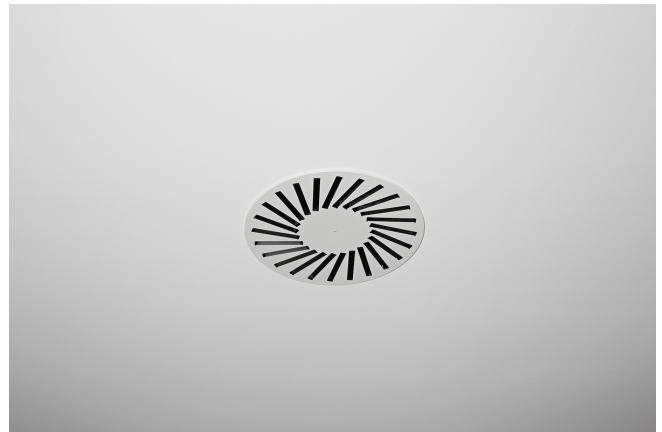

Installation and commissioning

- Preferably for rooms with a clear height up to 4.0 m
- Flush ceiling installation
- Freely suspended installation only with an extended border (supply air variant)
- Horizontal or vertical duct connection
- If necessary, carry out volume flow rate balancing with the damper element

These are only schematic diagrams to illustrate installation details.

Flush ceiling installation with square plenum box

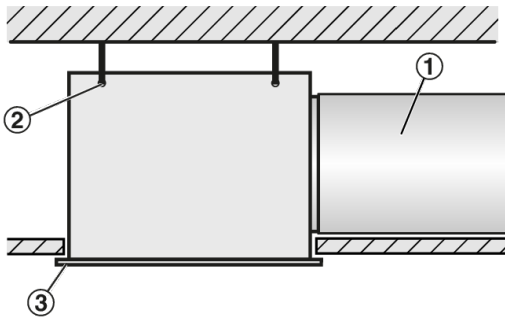

- ① Duct
- ② Suspension hole
- ③ Diffuser face
- Horizontal duct connection
- 4 Suspension holes
- Suspension with cords, wires or hangers, to be provided by others

Flush ceiling installation with circular plenum box

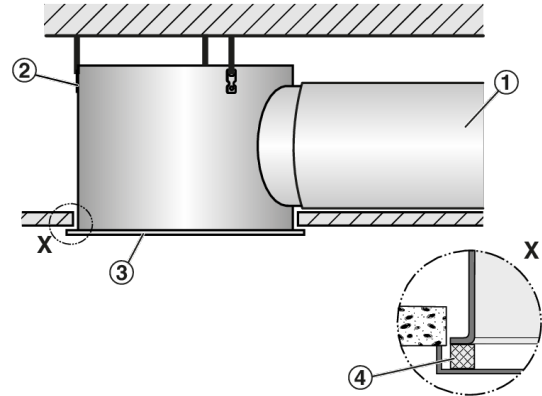

- ① Duct
- ② Suspension lug
- ③ Diffuser face
- Horizontal duct connection
- 3 Suspension lugs
- Suspension with cords, wires or hangers, to be provided by others

Freely suspended installation

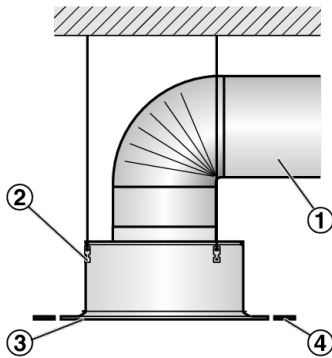

- ① Duct
- ② Suspension lug
- ③ Diffuser face
- ④ Extended border
- Vertical duct connection
- 3 Suspension lugs
- Suspension with cords, wires or hangers, to be provided by others

Diffuser face – sealing

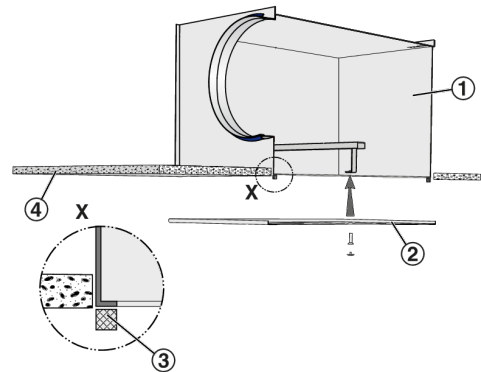

- ① Plenum box
- ② Diffuser face
- ③ Seal
- ④ Ceiling tile
- The self-adhesive sealing tape (supplied) has to be applied to the return edges of the plenum box by others

Diffuser face – central screw fixing

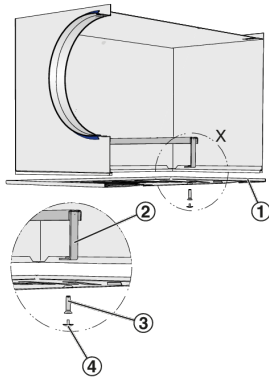

- ① Diffuser face
- ② Cross bar
- ③ Central fixing screw
- ④ Decorative cap

- Using the central fixing screw, fix the diffuser face to the cross bar of the plenum box
- Attach the decorative cap

Installation in metal ceilings

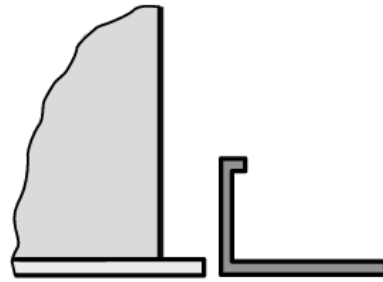

- Fix the plenum box to the ceiling
- Ceiling tile of the metal ceiling is independent of the air diffuser
- Fix the diffuser face after the ceiling has been completed

Installation in continuous ceilings

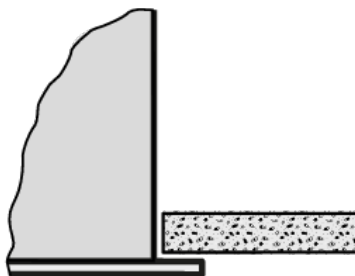

- Fix plenum box (including diffuser face, if necessary) to the ceiling
- Adjust plasterboard ceiling tile as required
- If necessary, fix the diffuser face after the ceiling has been completed

Installation in T-bar ceilings

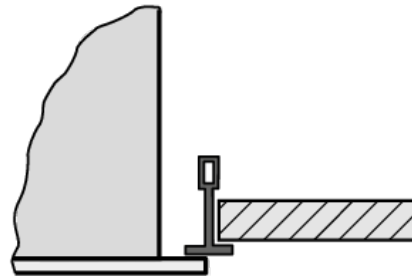

- Fix the plenum box to the ceiling
- The T-bar ceiling is independent of the ceiling diffuser
- Fix the diffuser face below the T-bars after the ceiling has been completed

Volume flow rate balancing

When several diffusers are connected to just one volume flow controller, it may be necessary to balance the volume flow rates.

- Ceiling diffusers with square plenum box and damper blade (variant -M): The diffuser face can be removed to access the damper blade; the damper blade can then be set to any position between 0 and 90°
- Ceiling diffusers with square plenum box, damper blade and pressure tap (variant -MN): The diffuser face need not be removed as the damper blade can be set with two cords (white and green).

Volume flow rate measurement

Ceiling diffusers with square plenum box, damper blade and pressure tap (variant -MN) allow for volume flow rate balancing even with the diffuser face in place.

- Connect the measuring tube to the digital manometer
- Read the effective pressure
- Read the volume flow rate off the characteristic or calculate it
- If necessary, adjust the damper blade position with the cords

A characteristic is included with each plenum box.

AK-Uni-...-MN Volume flow rate balancing

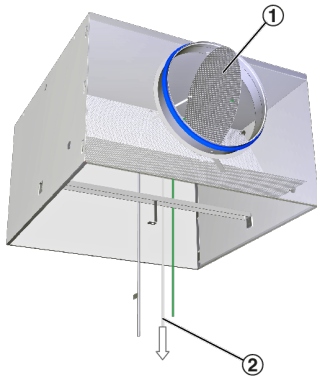

- ① Damper blade
 - ② White cord for opening the damper blade
- Open, 0°

AK-Uni-...-MN Volume flow rate balancing

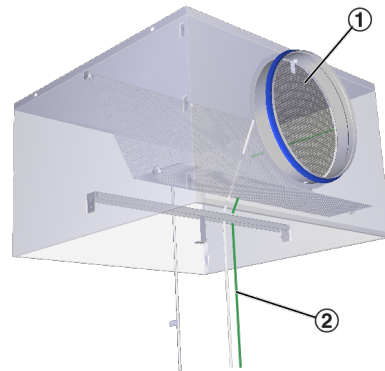

- ① Damper blade
 - ② Green cord for closing the damper blade
- Closed, 90°

AK-Uni-...-MN volume flow rate measurement

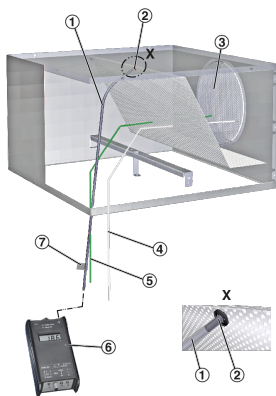

- ① Measuring tube
- ② Pressure tap
- ③ Damper blade for volume flow rate balancing
- ④ White cord for opening the damper blade
- ⑤ Green cord for closing the damper blade
- ⑥ Digital manometer
- ⑦ Text label indicating plenum box variant

Volume flow rate calculations

$$\textcircled{1} \quad q_v = C \times \sqrt{\Delta p_w}$$

$$\textcircled{2} \quad q_v = C \times \sqrt{\Delta p_w} \times \sqrt{\frac{1.2}{\rho}}$$

- ① For an air density of 1.2 kg/m
- ② For other air densities

Nomenclature

A [mm]

Position of the spigot, defined by the distance of the spigot centre line to the lower edge of the plenum box.

A_{eff} [m²]

Effective air discharge area

C [mm]

Length of the spigot

∅D [mm]

Outer diameter of the spigot

∅D₁ [mm]

Outer diameter of a circular diffuser face

∅D₂ [mm]

Diameter of a circular diffuser face style

∅D₃ [mm]

Diameter of a circular plenum box

H₁ [mm]

Height of diffuser face

H₃ [mm]

Height of plenum box

L_{WA} [dB(A)]

A-weighted sound power level of air-regenerated noise

m [kg]

Weight

NS [mm]

Nominal size

Δp_t [Pa]

Total differential pressure

□Q₁ [mm]

Outer diameter of a square diffuser face

□Q₃ [mm]

Dimensions of a square plenum box

q_v [m³/h]; [l/s]

Volume flow rate

Δt_z [K]

Supply air to room air temperature difference, i.e. supply air temperature minus room temperature

Lengths

Lengths are given in [mm] unless stated otherwise.

All sound power levels are based on 1 pW.